

MOTOPLASTIC, S.A.

Molí de la sal, 1 - 08403 Granollers (Barcelona) SPAIN

Tel. 34 93 849 06 33 - Fax 34 93 849 09 88

info@puig.tv - info@puigusa.com

www.puig.tv - www.puigusa.com

CARENABRÍS MODELO  
WINDSHIELD MODEL  
WINDSCHUTZ MODELL

## STREAM UNIVERSAL

**Ref.: 5022**  
(color negro/black colour/Farbe Schwarz)  
(color ahumado/smoke colour/Farbe Getönt)  
(color ahumado oscuro  
/dark smoke colour/Farbe Stark Getönt)  
(color azul/blue colour/Farbe Blau)



| ID. | DESCRIPCIÓN                   | DESCRIPTION             | BEZEICHNUNG                | QTY. |
|-----|-------------------------------|-------------------------|----------------------------|------|
| 1   | Pantalla                      | Windshield              | Scheibe                    | 1    |
| 2   | Tuerca M5 DIN982 Inox         | M5 DIN982 Inox nut      | M5 DIN982 Inox Mutter      | 4    |
| 3   | Tornillo phillips M5x13       | M5x13 phillips screw    | M5x13 Phillips Schraube    | 4    |
| 4   | Tornillo M5x20 DIN912 Inox    | M5x20 DIN912 Inox screw | M5x20 DIN912 Inox Schraube | 4    |
| 5   | Brida rótula                  | Ball bearing bridle     | Flansch-Kugelgelenk        | 2    |
| 6   | Semi-casquillo manillar Ø22mm | Medium-spacer Ø22mm     | Buchse Ø22mm               | 2    |
| 7   | Semi-casquillo manillar Ø26mm | Medium-spacer Ø26mm     | Buchse Ø26mm               | 2    |
| 8   | Tornillo M6x50 DIN912 Inox    | M6x50 DIN912 Inox screw | M6x50 DIN912 Inox Schraube | 2    |
| 9   | Tuerca M6 DIN982 Inox         | M6 DIN982 Inox nut      | M6 DIN982 Inox Mutter      | 2    |
| 10  | Guía varilla                  | Rod guide               | Stangenführung             | 2    |
| 11  | Brida Manillar Ø29mm          | Handlebar bridle Ø29mm  | Lenkerflansch Ø29mm        | 2    |
| 12  | Pasador Inox                  | Barrette Inox           | Inox Stift                 | 2    |
| 13  | Varilla con rótula            | Rod with ball bearing   | Stangen-Kugelgelenk        | 2    |
| 14  | Tapa exterior                 | Exterior cap            | Deckel                     | 2    |
| 15  | Tapa varilla                  | Bar cover               | Endkappen                  | 2    |
| 16  | Ribete                        | Trim                    | Kantenschutz               | 1    |

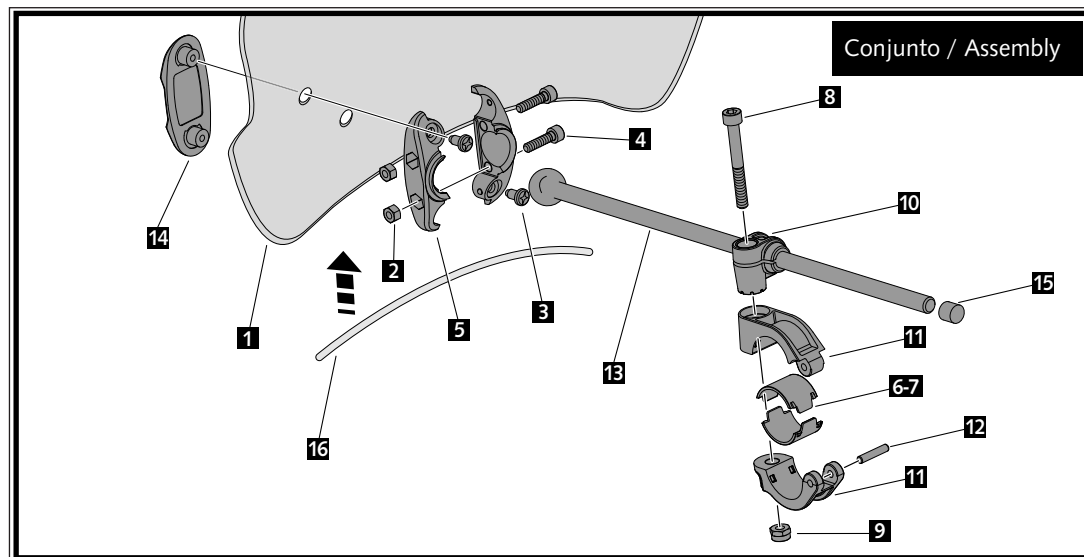

MOTOPLASTIC, S.A.

Molí de la sal, 1 - 08403 Granollers (Barcelona) SPAIN

Tel. 34 93 849 06 33 - Fax 34 93 849 09 88

info@puig.tv - info@puigusa.com

www.puig.tv - www.puigusa.com

En las revisiones del vehículo es conveniente efectuar también el mantenimiento de apriete de toda la tornillería del carenabrís, especialmente los tornillos que fijan éste al vehículo.

**Gracias por su atención.**

It would be convenient to re-tight the windshield screws, specially the ones that are fixed to the motorcycle, whenever you maintain the vehicle.

**Thanks for your attention.**

Wenn das Fahrzeug überholt wird sollten jedesmal auch alle Schrauben des Windschildes nachgezogen werden, vor allem die Schrauben die das Windschild an das Fahrzeug befestigen.

**Danke für Ihre Aufmerksamkeit.**

CONSULTAR EN NUESTRA PAGINA WEB LA DISPONIBILIDAD DEL VIDEO DE MONTAJE DE ESTA REFERENCIA /  
CONSULT OUR WEBSITE THE VIDEO MOUNT AVAILABILITY OF THIS REFERENCE

CARENABRÍS MODELO  
WINDSHIELD MODEL  
WINDSCHUTZ MODELL

## STREAM UNIVERSAL

**Ref.: 5022**  
(color negro/black colour/Farbe Schwarz)  
(color ahumado/smoke colour/Farbe Getönt)  
(color ahumado oscuro  
/dark smoke colour/Farbe Stark Getönt)  
(color azul/blue colour/Farbe Blau)

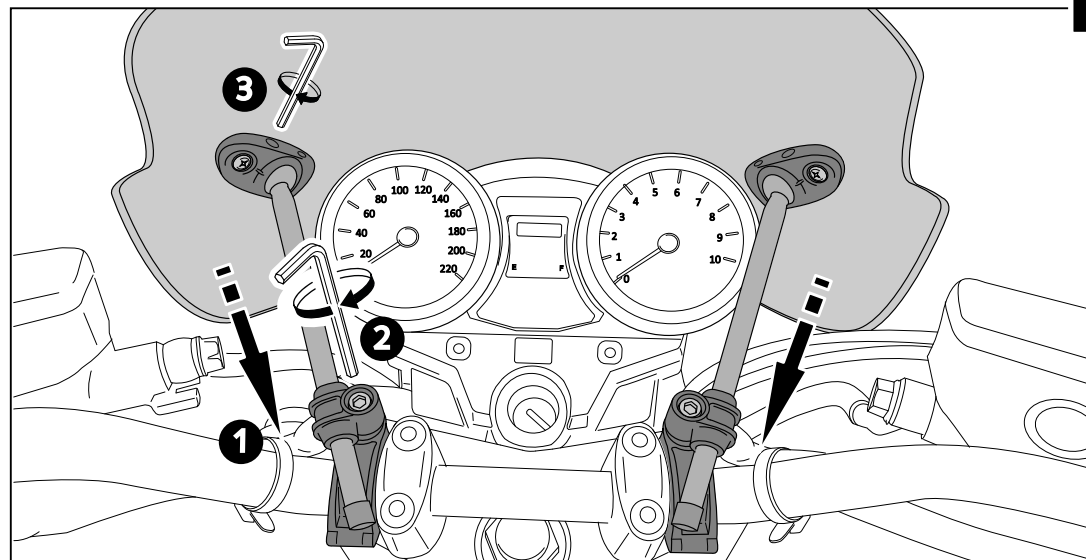
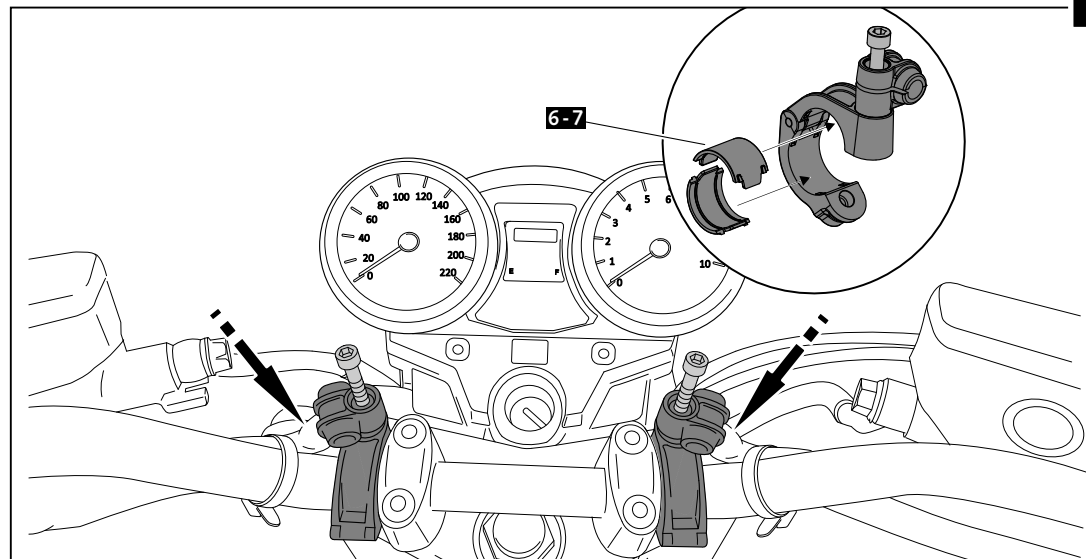



En las revisiones del vehículo es conveniente efectuar también el mantenimiento de apriete de toda la tornillería del carenabrís, especialmente los tornillos que fijan éste al vehículo.  
 Gracias por su atención.

It would be convenient to re-tight the windshield screws, specially the ones that are fixed to the motorcycle, whenever you maintain the vehicle.  
 Thanks for your attention.

In der Untersuchung des Fahrzeugs, überprüfen Sie die Schraubenverbindungen, besonders die Schrauben, die an dem Motorrad befestigt sind.  
 Danke für Ihre Aufmerksamkeit.

| ID. | DESCRIPCIÓN              | DESCRIPTION            | BEZEICHNUNG              | QTY. |
|-----|--------------------------|------------------------|--------------------------|------|
| 1   | Varilla 115mm            | Varill 115mm           | 115mm Stange             | 2    |
| 2   | Tornillo M8x50 DIN912    | M8x50 DIN912 screw     | M8x50 DIN912 Schraube    | 2    |
| 3   | Casquillo diam.14x12     | Metal arrowhead Ø14x12 | Buchse Durchmesser 14x12 | 2    |
| 4   | Soporte metálico c/negro | Metalic support        | Metallhalterung          | 2    |

## INSTRUCCIONES DE MONTAJE MOUNTING INSTRUCTIONS - MONTAGEANLEITUNG

KIT RAFALE / STREAM / TOURING II

Ref.: 10449

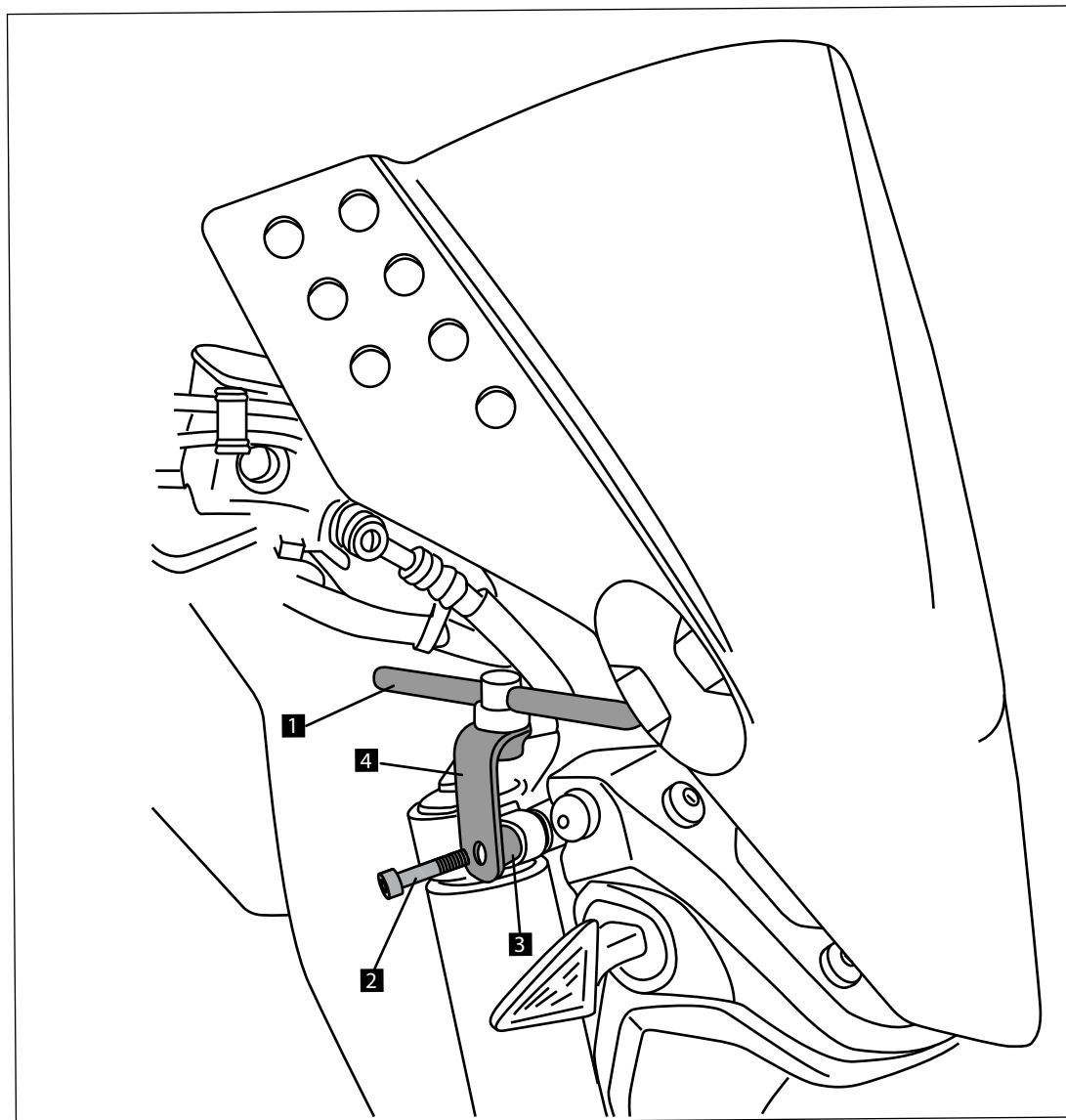

# VISERA MULTIREGULABLE MULTI-ADJUSTABLE VISOR

CÚPULA TIPO  
TYPE WINDSCREEN **A**



CÚPULA TIPO  
TYPE WINDSCREEN **B**



CÚPULA TIPO  
TYPE WINDSCREEN **C**



Ref.: 6007

Ref.: 5852

Ref.: 5853

Ahumado/Smoke

Transparente/Clear

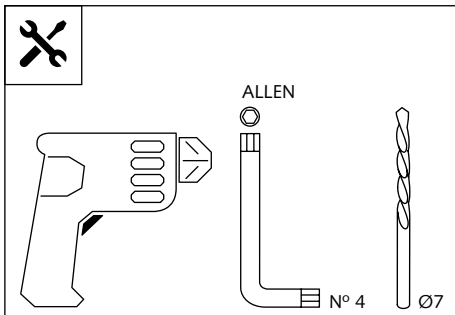

1 persona  
1 person



15 min

Fácil - Easy

Media-Intermediate

Difícil-Difficult

**Nota/Note:**

Si la visera se suministra con la cúpula Puig, no será necesario realizar los agujeros por que ya vienen incorporados.  
If the visor is supplied along with the windscreen, the windscreen will come factory-drilled so no drilling is necessary.

| ID. | PIEZA / PART | DESCRIPCIÓN                   | DESCRIPTION                   | QTY. |
|-----|--------------|-------------------------------|-------------------------------|------|
| 1   |              | Visera                        | Visor                         | 1    |
| 2   |              | Plantilla                     | Template                      | 1    |
| 3   |              | Mecanismo multiregulable      | Multi-adjustable mechanism    | 2    |
| 4   |              | Tapeta                        | Cap                           | 4    |
| 5   |              | Tornillo rosca plástico M6x12 | Plastic thread fastener M6x12 | 8    |

# VISERA MULTIREGULABLE MULTI-ADJUSTABLE VISOR

INSTRUCCIONES DE MONTAJE - MOUNTING INSTRUCTIONS - MONTAGEANLEITUNG

TIPO/TYPER A - TIPO/TYPER A - TIPO/TYPER A

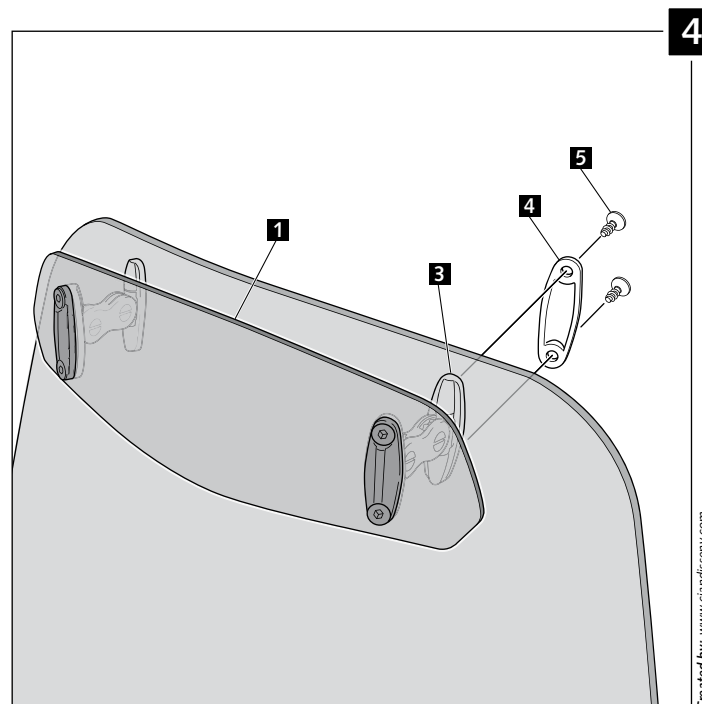
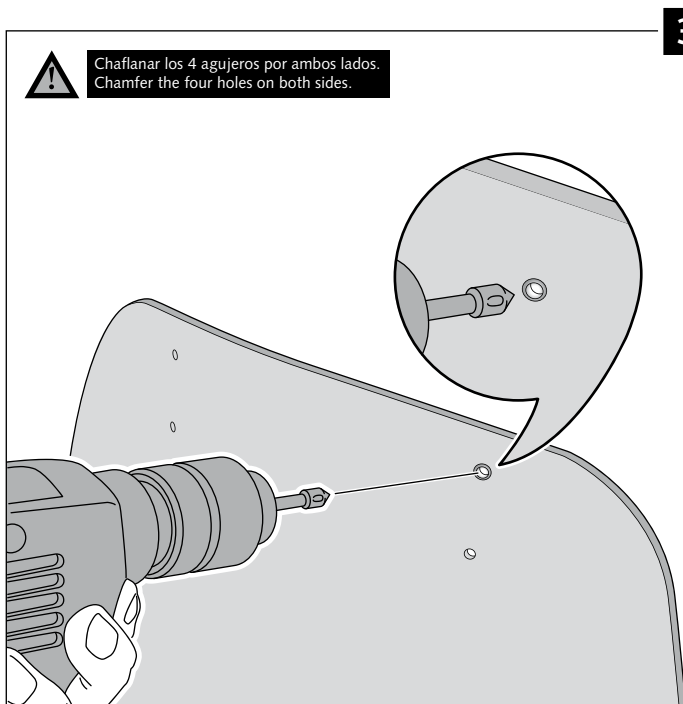
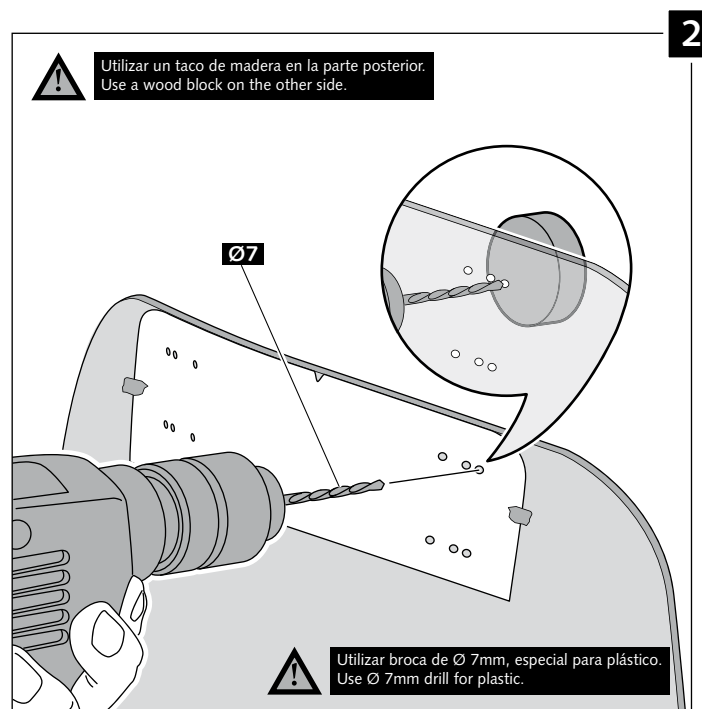
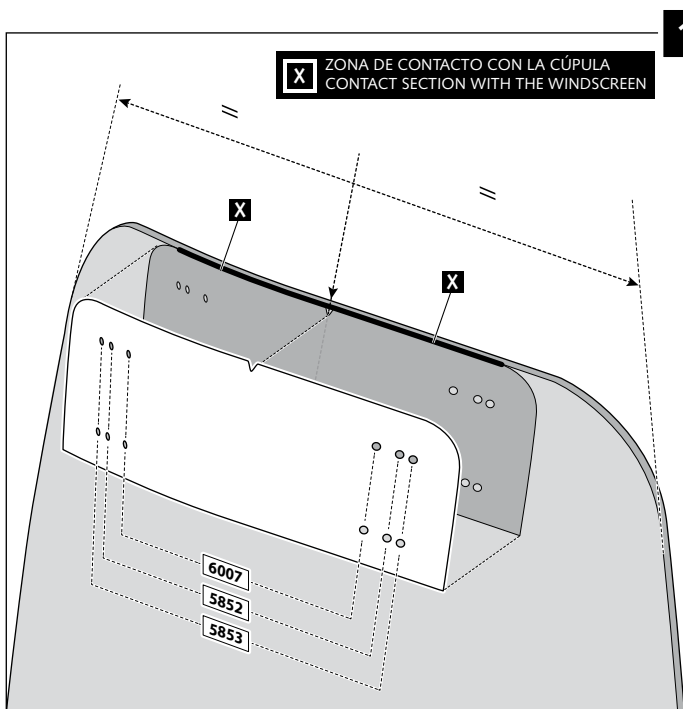

# VISERA MULTIREGULABLE MULTI-ADJUSTABLE VISOR

INSTRUCCIONES DE MONTAJE - MOUNTING INSTRUCTIONS - MONTAGEANLEITUNG

TIPO/TYPE B - TIPO/TYPE B - TIPO/TYPE B

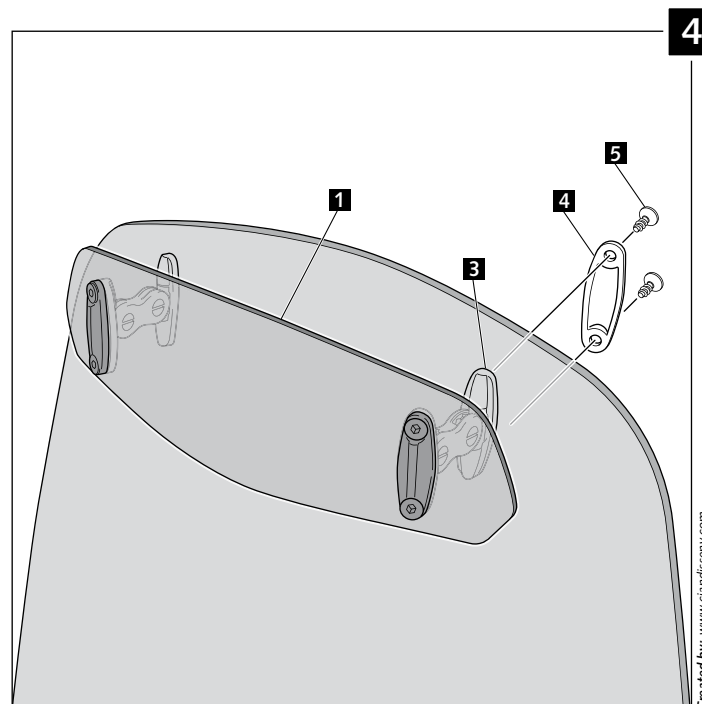
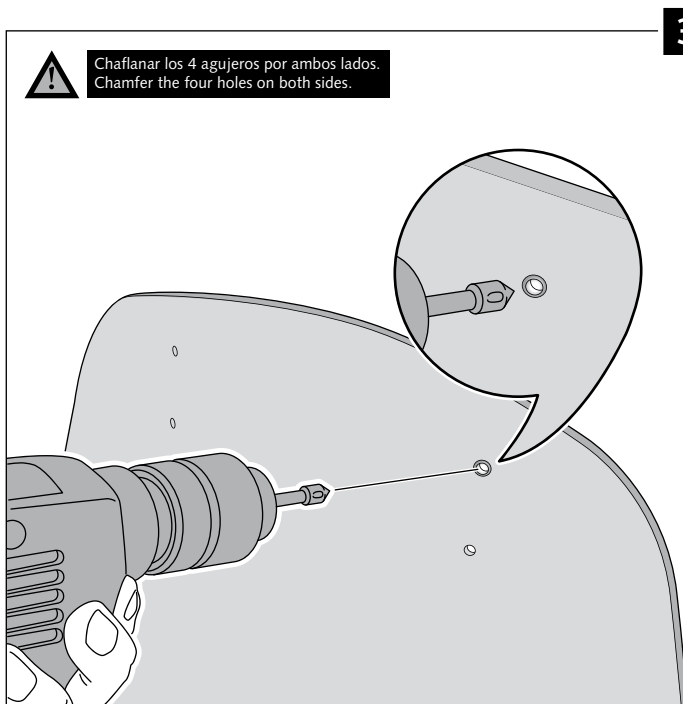
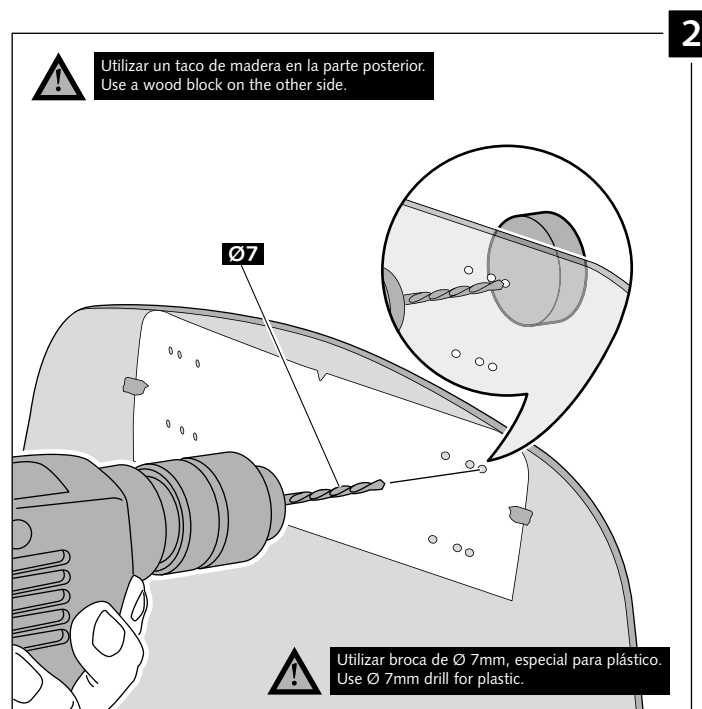
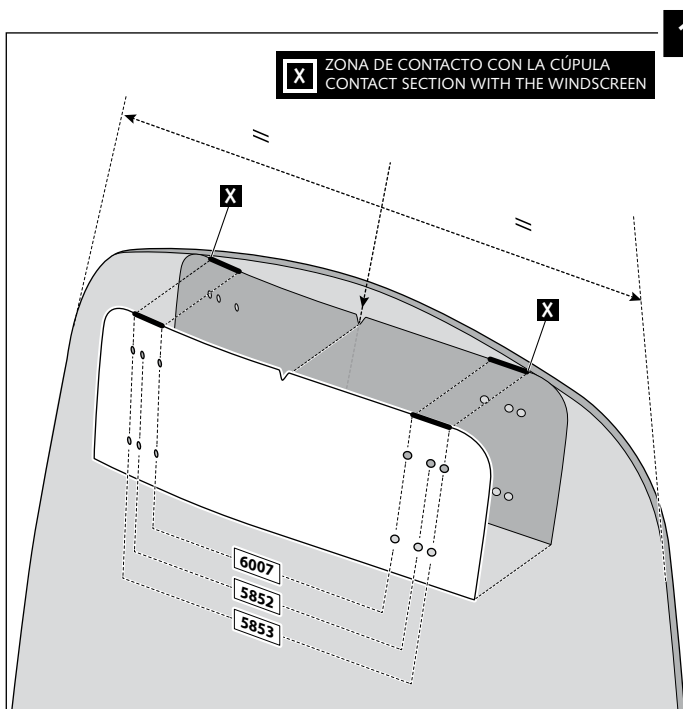

# VISERA MULTIREGULABLE MULTI-ADJUSTABLE VISOR

INSTRUCCIONES DE MONTAJE - MOUNTING INSTRUCTIONS - MONTAGEANLEITUNG

TIPO/TYPER C - TIPO/TYPER C - TIPO/TYPER C

