

# KTM 990 DUKE '24- / 1290 SUPERDUKE R '14- / 1390 SUPERDUKE R '24-

## M O U N T I N G I N S T R U C T I O N S

REF 21908

BRAKE COOLER



1 Person



40 min



EASY



TORX  
T30  
T40

ALLEN  
Nº 3  
Nº 6

ID	PIEZA/PART	DESCRIPCIÓN	DESCRIPTION	QTY	REF
1		Brake cooler derecho	Right brake cooler	1	21908J/CM3
2		Brake cooler izquierdo	Left brake cooler	1	21908J/CM3
3		Soporte aluminio derecho trasero (º)	Rear right aluminum support (º)	1	SOPOR6P3RT21908
4		Soporte aluminio derecho inferior (º)	Lower right aluminum support (º)	1	SOPOR6P3RI215908
5		Soporte aluminio derecho superior (º)	Upper right aluminum support (º)	1	SOPOR6P3RS21908
6		Soporte aluminio izquierdo trasero	Rear left aluminum support	1	SOPOR6P3LT21908
7		Soporte aluminio izquierdo inferior	Lower left aluminum support	1	SOPOR6P3LI21908
8		Soporte aluminio izquierdo superior	Upper left aluminum support	1	SOPOR6P2LS21908
9		Tornillo Allen M8x35 DIN912	M8x35 DIN912 Allen screw	4	TORNI-AD912-196
10		Casquillo Ø13x Ø8,5 x12	Ø13x Ø8,5 x12 Arrowhead	4	CASQUI-M----769
11		Casquillo Ø13x Ø8,5 x3,5	Ø13x Ø8,5 x3,5 Arrowhead	2	CASQUI-----775
12		Tornillo Allen M5x16 ISO 7380	M5x16 ISO 7380 Allen screw	4	TORNI-I7380-493
13		Tapón tornillo M5 ISO 7380	M5 ISO 7380 Screw cap	6	TAPON-----85
14		Tornillo Allen M5x12 Ø11 ISO 7380	M5x12 Ø11 ISO 7380 Allen screw	4	TORNI-AI-----520
15		Arandela de nylon M5	M5 Nylon washer	6	ARNV000000000245
16		Arandela de goma Ø4,5 x Ø11 x 2mm	Ø4,5 x Ø11 x 2mm Rubber washer	6	ARAND-EPDM--722
17		Tuerca M5 DIN 982 autoblocante	M5 DIN982 Locknut	2	TUERCA-D982-746

# KTM 990 DUKE '24- / 1290 SUPERDUKE R '14- / 1390 SUPERDUKE R '24-

## INSTRUCCIONES DE MONTAJE - MOUNTING INSTRUCTIONS - MONTAGEANLEITUNG

**1**

DISASSEMBLY  
DESMONTAJE

Se muestra el montaje del lado derecho a modo de ejemplo, realizar los mismos pasos para el montaje del lado izquierdo.  
The right side assembly is shown as an example, so the same steps can be performed for the left side assembly.

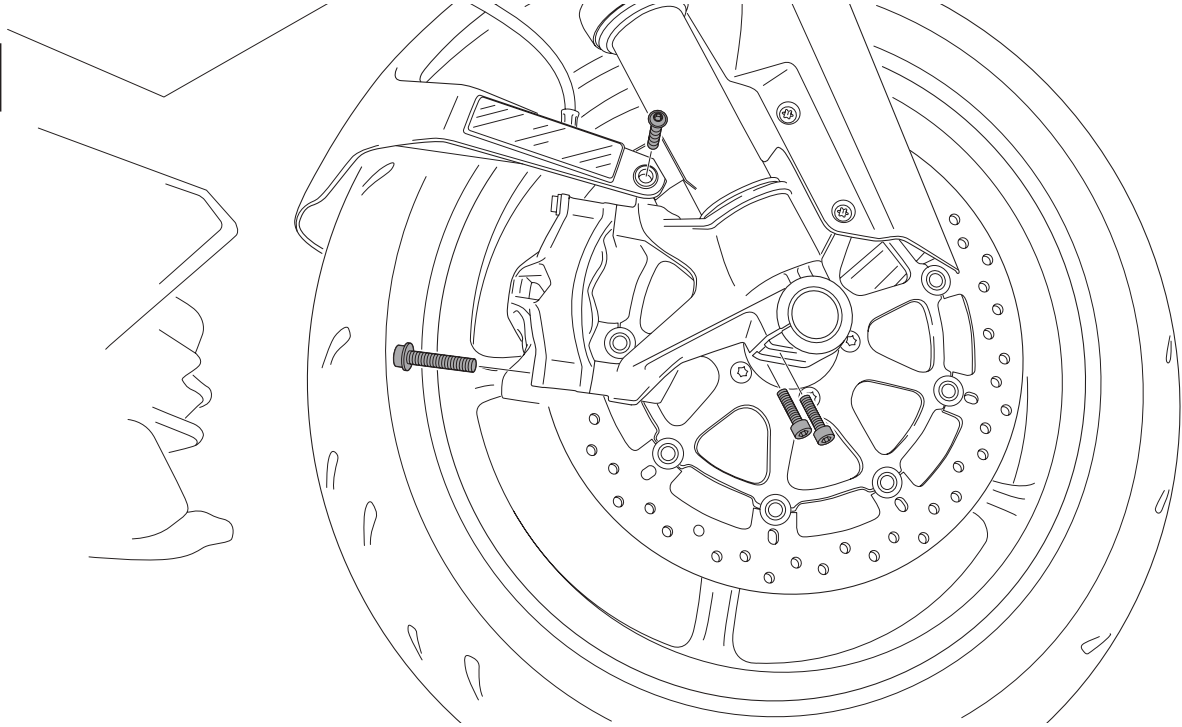

**2**

ASSEMBLY  
MONTAJE

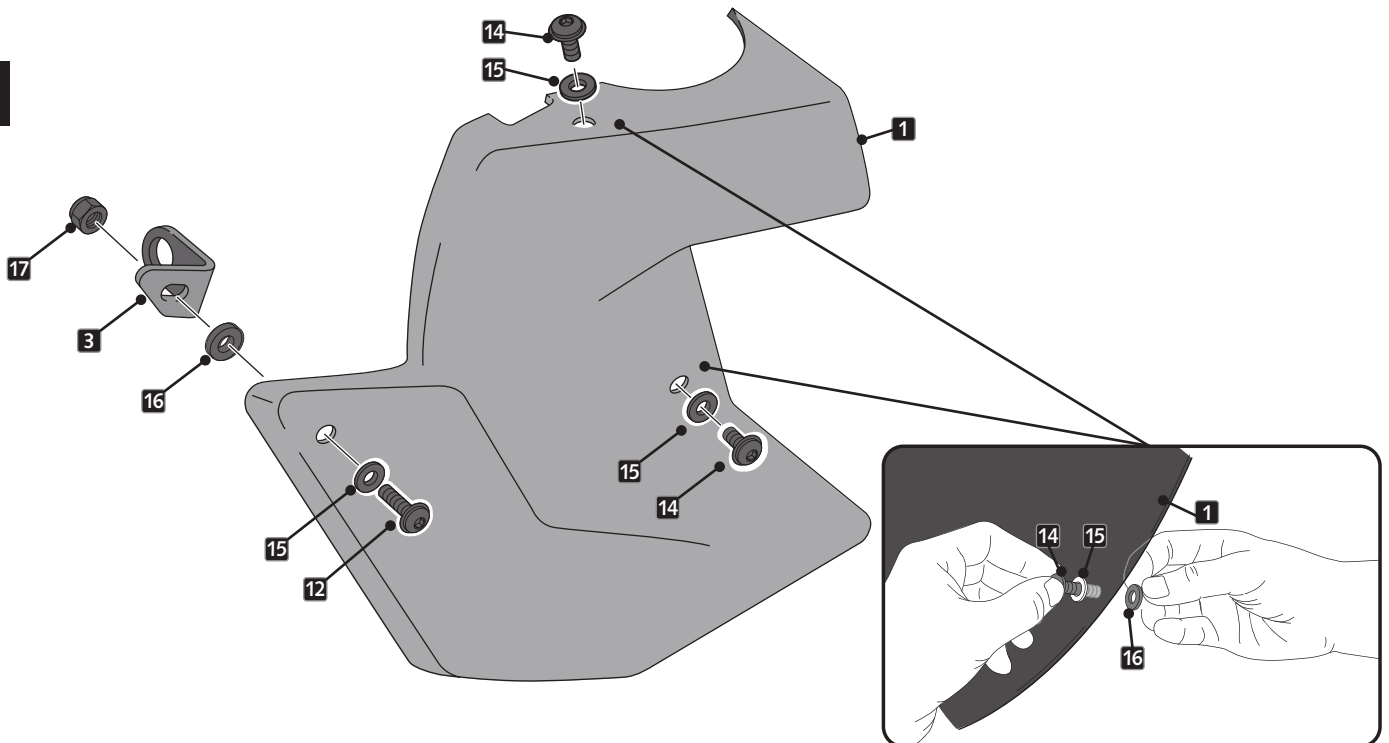

# KTM 990 DUKE '24- / 1290 SUPERDUKE R '14- / 1390 SUPERDUKE R '24-

INSTRUCCIONES DE MONTAJE - MOUNTING INSTRUCTIONS - MONTAGEANLEITUNG

**3**

ASSEMBLY  
MONTAJE

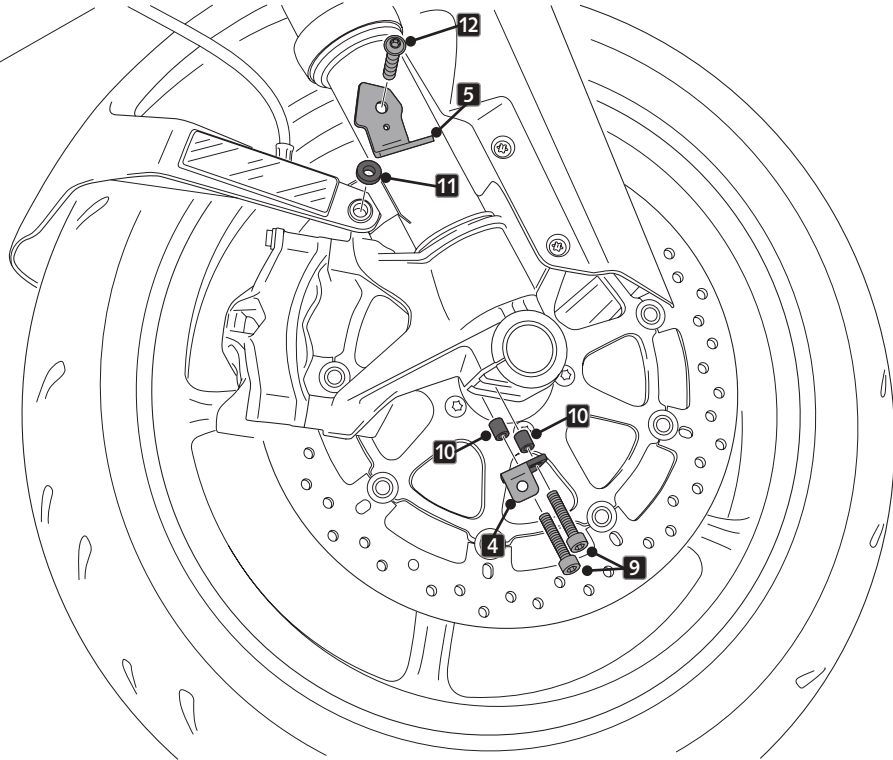

**9** Par de apriete - 15 Nm  
Tightening torque - 15Nm

**12** Par de apriete - 3,5 Nm  
Tightening torque - 3,5 Nm

**4**

ASSEMBLY  
MONTAJE

**A** PIEZA ORIGINAL  
ORIGINAL PART

**A** Par de apriete - 45 Nm  
Tightening torque - 45Nm

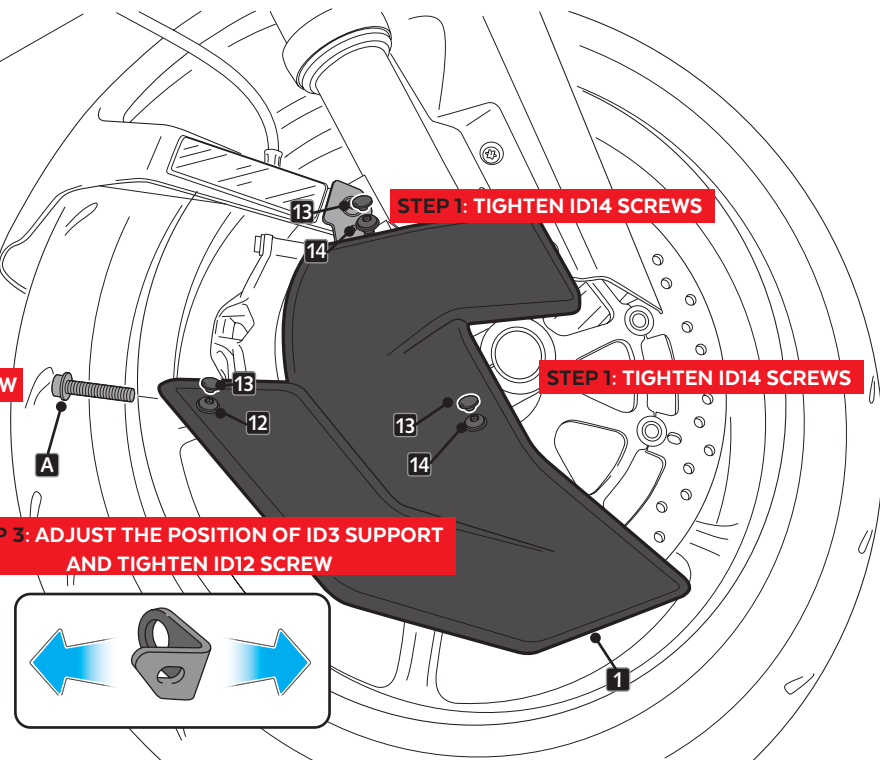

**12** Par de apriete - 3,5 Nm  
Tightening torque - 3,5 Nm

**14** Par de apriete - 3 Nm  
Tightening torque - 3 Nm