

BMW S1000RR '23-

M O U N T I N G I N S T R U C T I O N S

REF 21569

REAR SEAT COWL

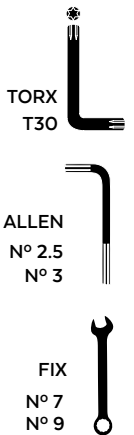

ID.	PIEZA/PART	DESCRIPCIÓN	DESCRIPTION	QTY.	REF.:
1		Colín	Rear seat cowl	1	21569J/CM3
2		Colín superior	Upper rear seat cowl	1	21569J/CM3
3		Soporte fijación moto	Motorcycle fixing support	1	SOPOR4P30M21569
4		Soporte colín delantero superior	Upper front rear seat cowl support	1	SOPOR4P30S21569
5		Soporte colín delantero inferior	Lower front rear seat cowl support	1	SOPOR4P30I21569
6		Soporte colín trasero	Rear rear seat cowl support	1	SOPOR4P30T21569
7		Perno de clip M4	M4 clip bolt	2	PERNOCLIP-21853
8		Tornillo allen M4x8 ISO7380	M4x8 ISO7380 Screw	2	TORNI-I7380-757
9		Tornillo allen M5x12 Ø11 ISO 7380	M5x12 Ø11 ISO 7380 Allen screw	2	TORNI-AI----520
10		Tornillo allen M5x25 Ø11 ISO 7380	M5x25 Ø11 ISO 7380 Allen screw	2	TORNI-I7380-766
11		Casquillo Ø8,5xØ13x3,5mm	Ø8,5xØ13x3,5 arrowhead	2	CASQUI-----775
12		Silentblock Ø9xØ6x8mm	Ø9xØ6x8mm Silentblock	2	AROPASACABLES-1
13		Tornillo M4x16 DIN7991	M4x16 DIN7991 screw	2	TORNI-D7991-935
14		Tuerca autoblocante M4	M4 lock nut	2	TUERCAE985-0290
15		Kit adhesivos	Sticker set	1	ADHESI----20703
16		Espuma	Foam	1	ESPUMA----21569
17		Arandela M4 DIN9021	M4 DIN9021 Washer	2	ARAND-----862
18		Tapón M10 Ø9,8 x11mm	M10 Ø9,8 x11mm cap	2	TOPEGOMA--21569
19		Arandela de goma Ø4,5 x Ø11 x 2mm	Arandela de goma Ø4,5 x Ø11 x 2mm	2	ARAND-EPDM--722

BMW S1000RR '23-

INSTRUCCIONES DE MONTAJE - MOUNTING INSTRUCTIONS - MONTAGEANLEITUNG

1

DISASSEMBLY
DESMONTAJE

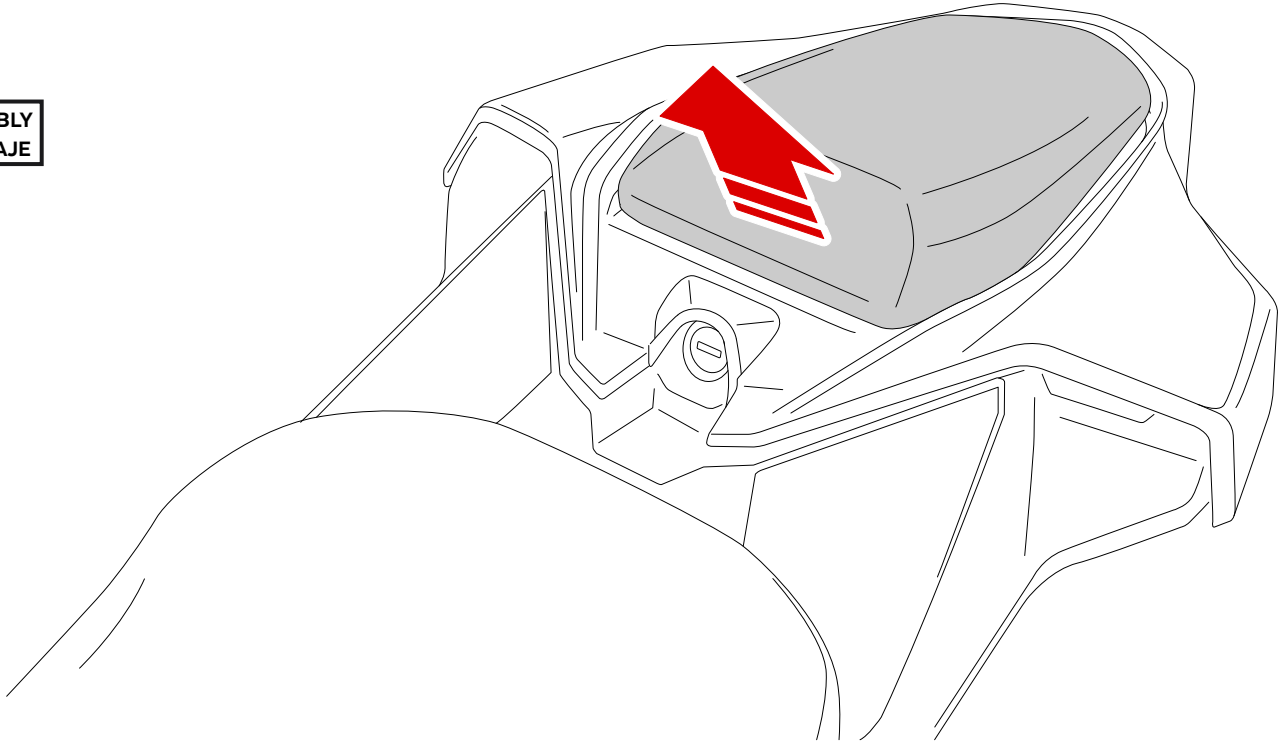

2

DISASSEMBLY
DESMONTAJE

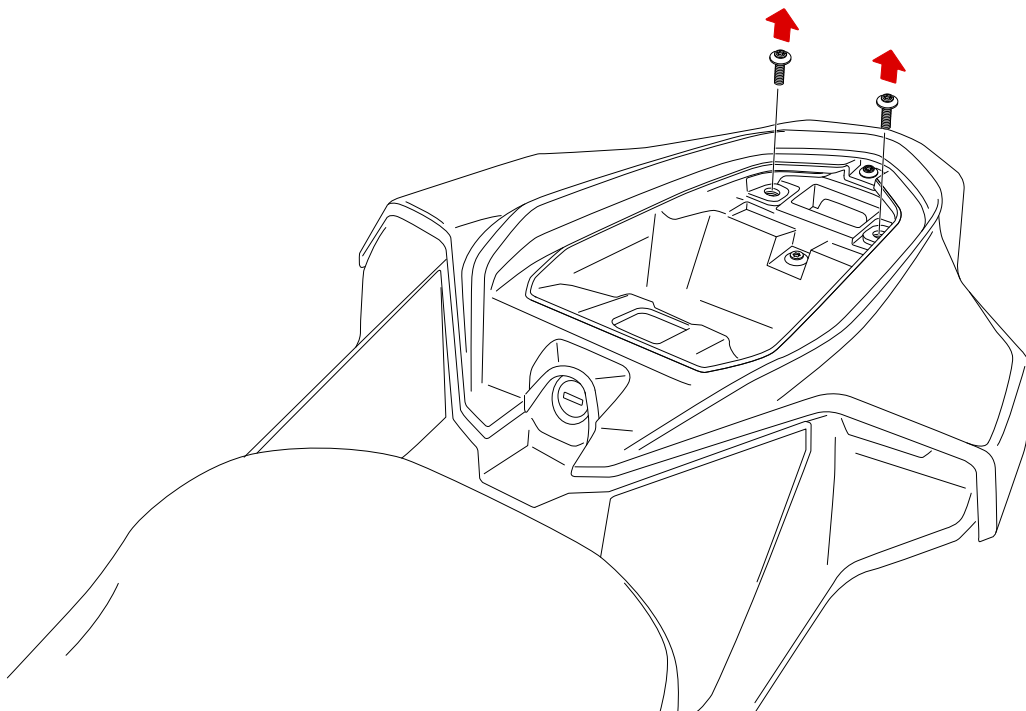

BMW S1000RR '23-

INSTRUCCIONES DE MONTAJE - MOUNTING INSTRUCTIONS - MONTAGEANLEITUNG

3

ASSEMBLY
MONTAJE

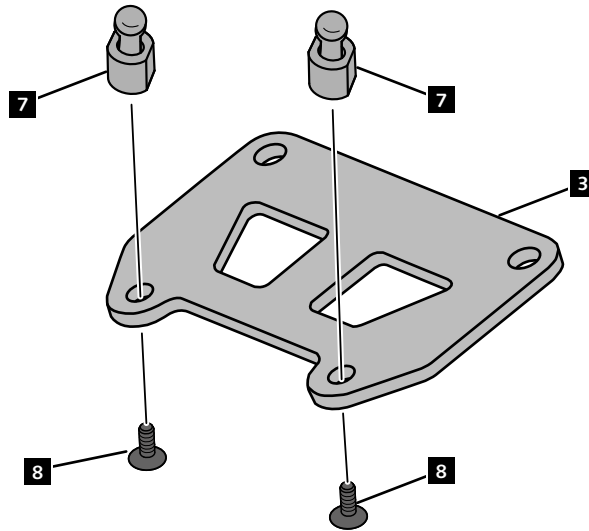

8



Par apriete - 2 Nm
Tightening torque - 2 Nm

4

ASSEMBLY
MONTAJE

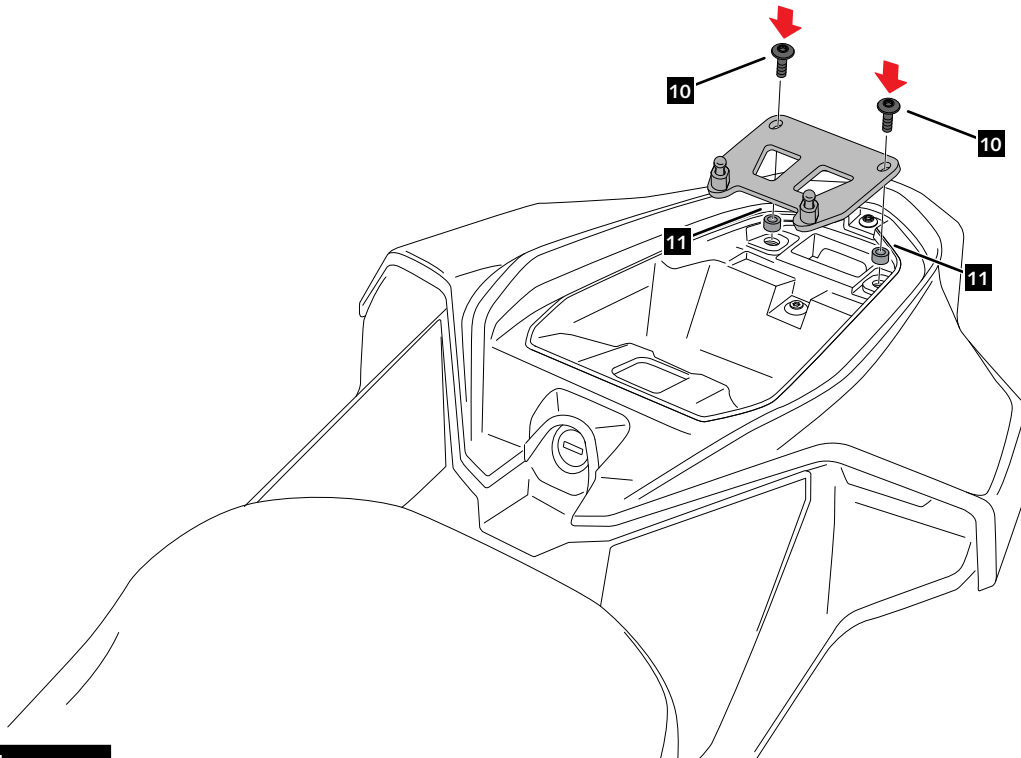

10



Par apriete - 3 Nm
Tightening torque - 3 Nm

BMW S1000RR '23-

INSTRUCCIONES DE MONTAJE - MOUNTING INSTRUCTIONS - MONTAGEANLEITUNG

5

ASSEMBLY
MONTAJE

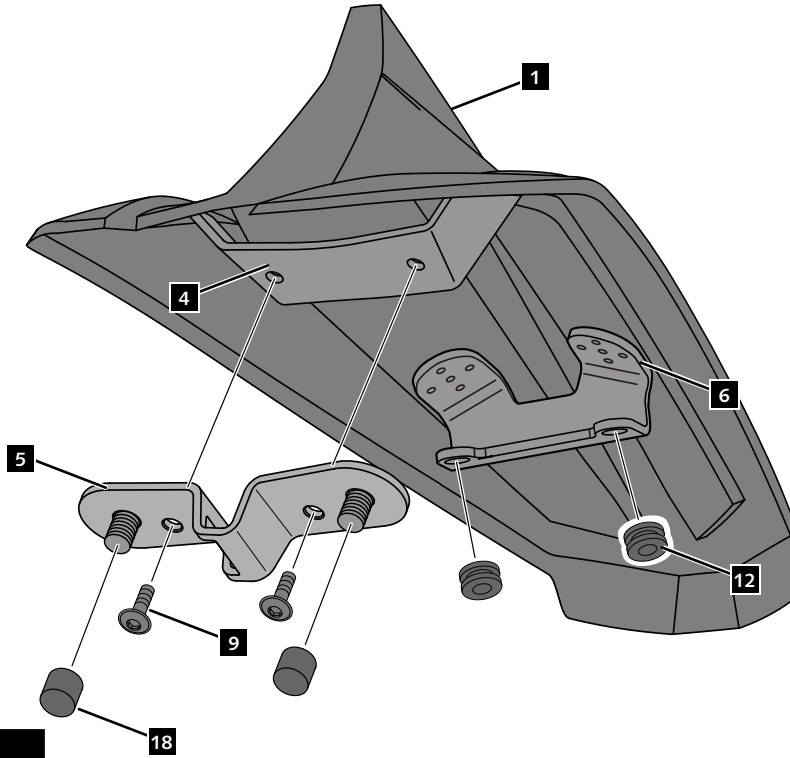

9



Par apriete - 3,5 Nm
Tightening torque - 3,5 Nm

6

ASSEMBLY
MONTAJE

ATTENTION!
ASSEMBLY
OPTION 1

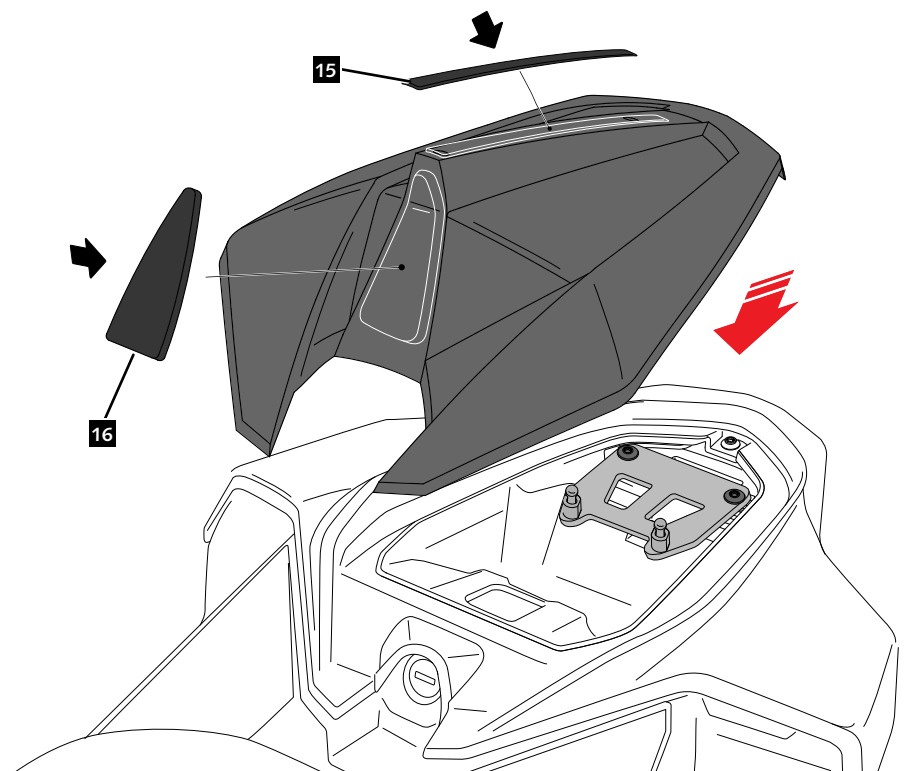
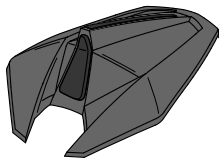

BMW S1000RR '23-

INSTRUCCIONES DE MONTAJE - MOUNTING INSTRUCTIONS - MONTAGEANLEITUNG

7

ASSEMBLY
MONTAJE

ATTENTION!
ASSEMBLY
OPTION 2

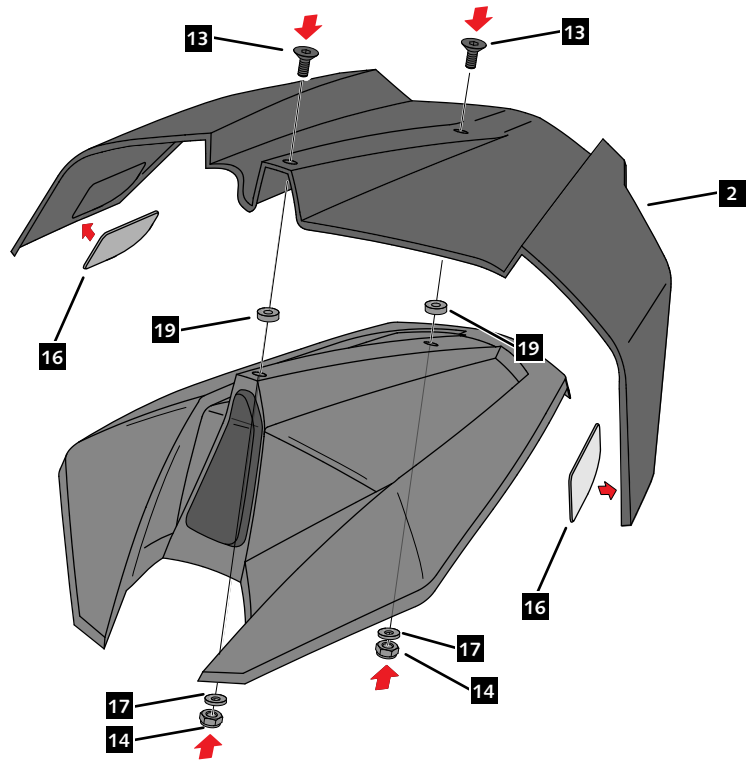
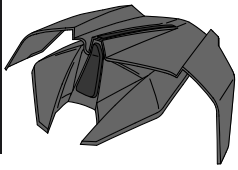

13



Par apriete - 2 Nm
Tightening torque - 2 Nm

8

ASSEMBLY
MONTAJE

