

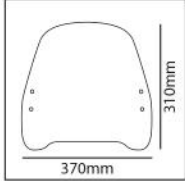

MOD. TRAFIC

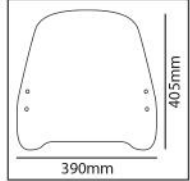

MOD. URBAN



### PREVENCIÓN

- Usar agua y jabón neutro para limpiar la pantalla.
- Revisar periódicamente el apriete de la tornillería.
- Estacionar el scooter en dirección al sol, evitando el efecto lupa que puede dañar algunas partes.
- Aparcar si es posible en superficies niveladas.

Gracias por su atención.

### PREVENTION

- Use water and neutral soap to clean the windshield.
- Check the tightening of the fasteners periodically.
- Park the scooter facing the sun, avoiding the sun-reflection effect that may damage some parts.
- Park if possible on even surfaces.

Thanks for your attention.

ID.	DESCRIPCIÓN	DESCRIPTION	QTY.
1	Pantalla	Windshield	1
2	Tapa exterior	Exterior cap	2
3	Soporte rótula exterior	Ball bearing exterior support	2
4	Soporte rótula interior	Ball bearing interior support	2
5	Tornillo allen M5x20 DIN912	M5x20 DIN912 allen screw	4
6	Tuerca M5 DIN982 autofrenado	M5 DIN982 lock nut	4
7	Tornillo phillips M5x13	M5x13 phillips screw	4
8	Varilla recta Ø9x130x90° para ref.20363	Straight rod Ø9x130x90° for ref.20363	2
8	Varilla Ø9x160 x90° para ref.20364	Rod Ø9x160 x90° for ref.20364	2
9	Tapón final varilla	Final bar cap	2
10	Tornillo M8x40 DIN912	M8x40DIN912 screw	2
11	Soporte guía sujección varilla	Rod guide support	2
12	Acoplamiento esquadra	Coupling angle	2
13	Esquadra Ref.:582	Angle Ref.:582	2
14	Caperuza plana M8	M8 nut cover	2
15	Fuelle tapa taladro	Below drill cover	2
16	Tuerca M8 DIN6923	M8 DIN6923 nut	2
17	Tapón tornillo M8 DIN912	M8 DIN912 screw cap	2
18	Alargo retrovisor (original)	Rear mirror extension (original)	2

## CARENABRÍS ADAPTABLE A - WINDSHIELD ADAPTABLE TO HONDA SCOPY SH125i '20- / SH350i '20-

Mod.: TRAFIC  
Ref.: 20363

Mod.: URBAN  
Ref.: 20364

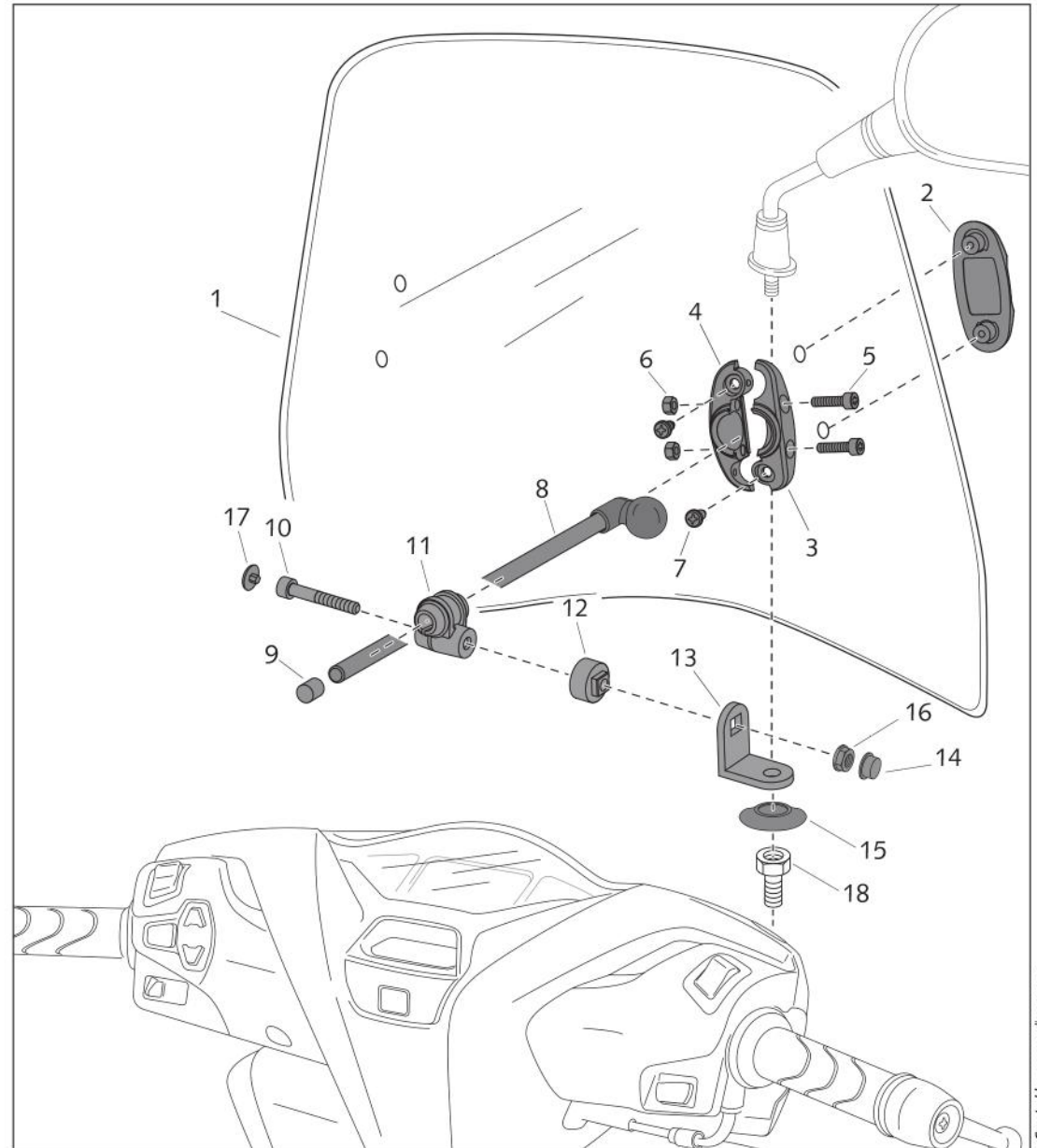

VER DORSO - LOOK BACK

